

Variable Terrain Installation

Calculate Rise/Foot Angle

To determine the hole enlargement size, first calculate the slope rise/foot or the angle of the slope. Refer to the diagram and examples.

- Measure section length in inches
- Determine section rise by using line level and measuring vertical rise; measure rise in inches
- Divide rise by section length to get rise per inch
- Multiply by 12 to determine rise per foot

Example: 24" rise ÷ 96" length = .25 rise per inch = 3" rise per foot

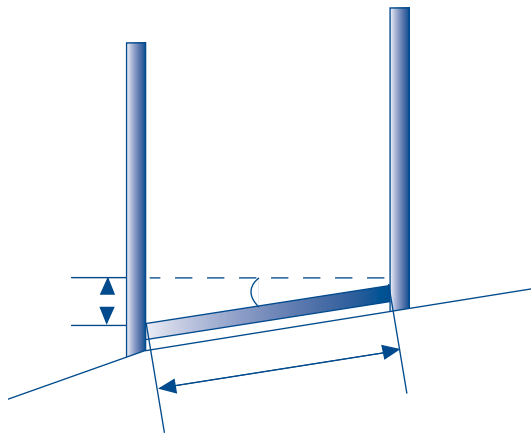

- Two methods for installing a fence on variable sloping terrain exist - stepping and racking
- For either method, divide slope evenly into all sections

Stepping Method

With the stepping method, the rails remain horizontal and the posts are extended to accommodate the variance in terrain. Longer end posts should be used and holes for opposite side of post can be field fabricated with template kit and router or spiral saw to accept rails.

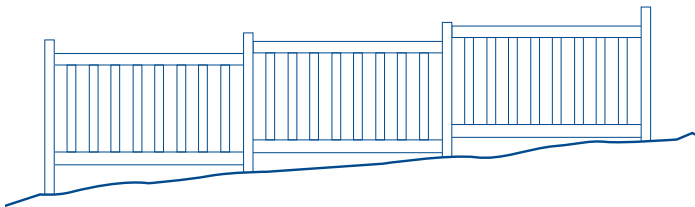

Racking Method - 10° or Less

With the racking method, the horizontal rails will follow the sloping terrain.

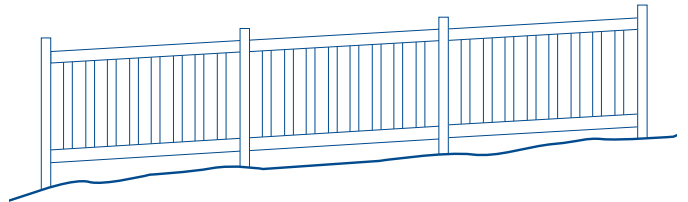

When installing multiple sections, it is advisable to use an End Post and field fabricate the opposite side of the post to avoid a jagged fence line.

Depending on severity of rack (and specific fence style), the following field fabrication may be necessary for proper installation.

1. Enlarge holes in post to accept rails
2. Enlarge holes in rail to accept pickets
3. Shorten picket length

NOTE: Depending on severity of rack, post centers may need to be decreased. Be sure to verify prior to setting posts.

1. Enlarge holes in post to accept rails
 - Determine angle or slope
 - Place first post in hole and hold plumb
 - Place rail next to post (not in routed hole) at correct angle of grade

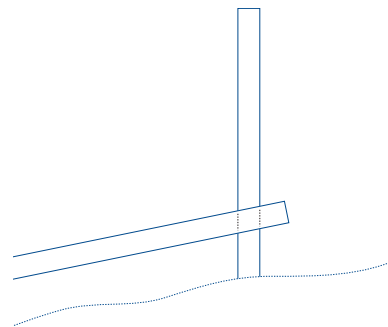

- Mark rail where post crosses it on angle
- Remove rail, measure the length of the drawn angle. Add 1/8" to this length to determine proper post hole size
- Enlarge post holes.

NOTE: Always open bottom of top hole and top of bottom hole to maintain proper fence height.

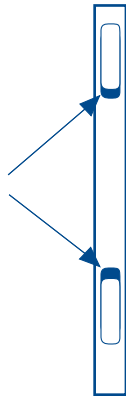

- For extreme racking situations, picket ends may need to be cut to accommodate rack
- Position top and bottom rails in routed post holes
- Position picket next to rails so it is plumb and aligned with bottom side of bottom rail
- Mark position where top of picket intersects with top of top rail; subtract 3/8" and cut picket to length

NOTE: For ribbed rails - top and bottom of picket will need to be aligned with internal rib.

- Holes may be cut utilizing a template kit and router or spiral saw
- Determine location of holes on opposite side of line post by laying post across side of rail (align with routed hole) and marking exit position of rail on opposite side of post
- Cut holes with template kit and router or spiral saw as previous

2. Enlarge holes in rail to accept picket

- Position rail at desired angle
- Hold picket plumb against side of rail
- Mark picket where rail crosses it on angle

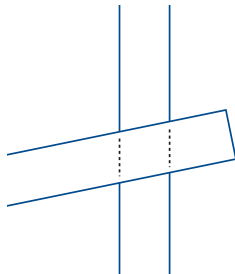

- Measure the length of the drawn angle and add 1/8" to this length to determine proper rail hole size
- Enlarge holes with a spiral saw

NOTE: Always cut the same side of each hole to maintain spacing

3. Shorten picket length

Post Routing Template Kit

Routing template kit can be used to enlarge holes for racking as well as to create transitions for stepping, changing heights or styles.

Install 3/8" router blade and 5/8" bearing or router guide. Any substitutions may result in improper hole size or damage to the template kit.

NOTE: Template cutout size is designed to be 1/8" larger than the finished cut to allow bearing to follow the shape.

Select the appropriate template for the application.

Assemble the template as shown, configured for the desired post size (4" or 5").

NOTE: It is advisable to practice routing on a scrap piece before attempting actual cut.

Mark location of hole to be routed. Offset template cut by 1/8" to allow for bearing (i.e., if hole is to be located 3" from top of post, position edge of template 2-7/8" from top).

Tighten wing nuts. Place on a flat, firm surface to prevent tipping.

Route hole per manufacturer's recommendations.

ALWAYS WEAR SAFETY GLASSES.

Loosen wing nut and remove template.

For situations that require a larger hole to accommodate racking, route a standard hole, loosen wing nuts and slide template to new position to route excess material.

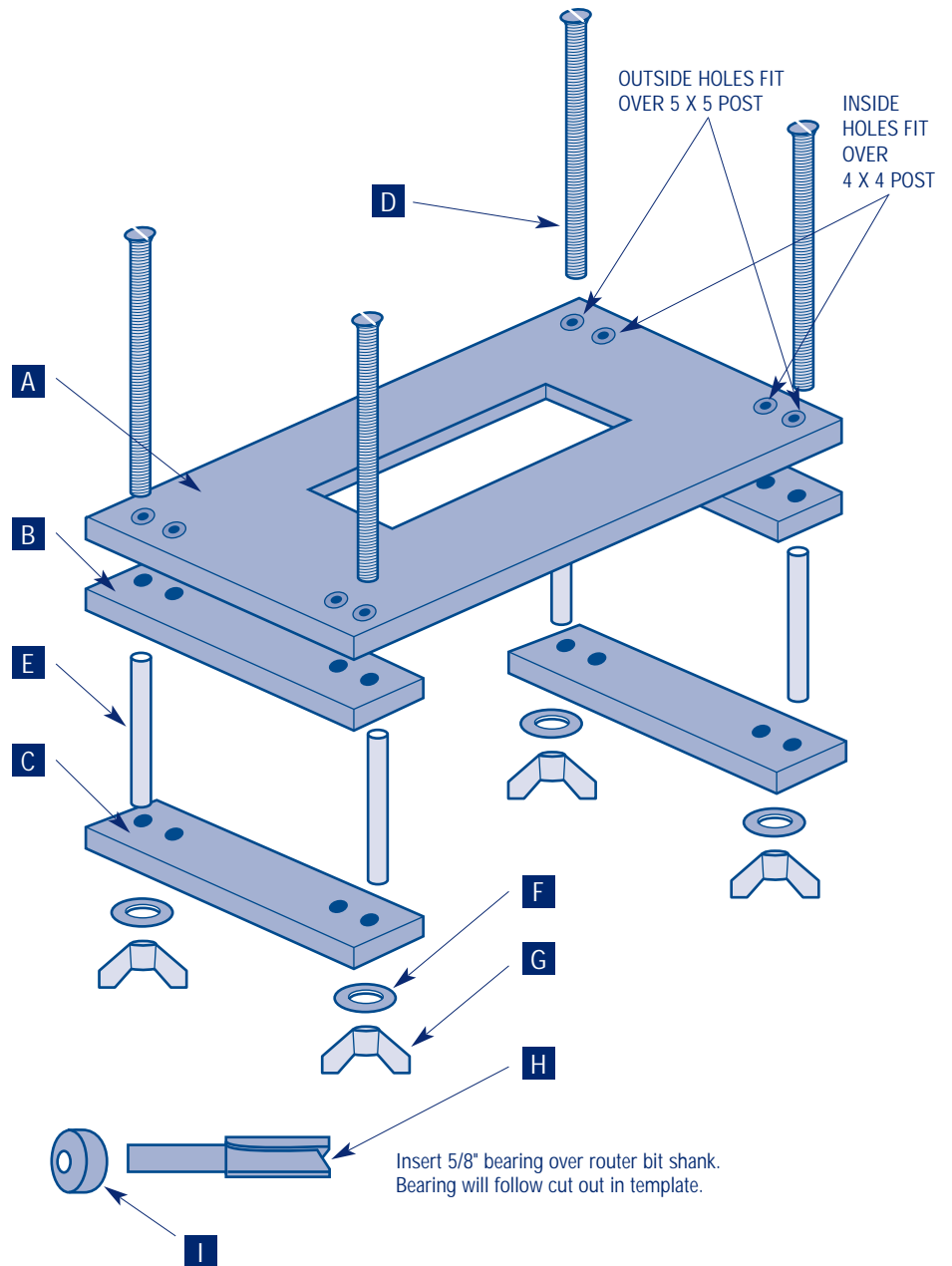

- A** ROUTING TEMPLATE
- B** 1-1/8" TEMPLATE SPACER PLATE
- C** 1-1/2" TEMPLATE SPACER PLATE
- D** 1/4" -20 X 6" BOLTS
- E** 3/8" OD PLEXI TUBE
- F** 1/4" FLAT WASHER
- G** 1/4" -20 WING NUT
- H** 3/8" ROUTER BIT W/ 1/4" SHANK
- I** 5/8" BEARING W/ 1/4" ID OPENING